



3-Phase Ground Fault Display

ORDERING INFORMATION

MODEL NUMBER	DESCRIPTION
GFD-100	Vertical Mount
GFD-200	Horizontal Mount

DIMENSIONS (INCHES)

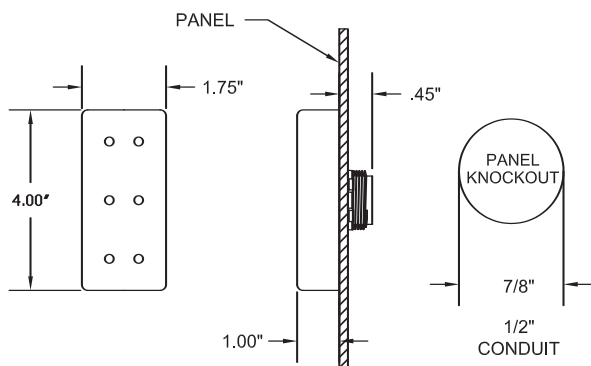
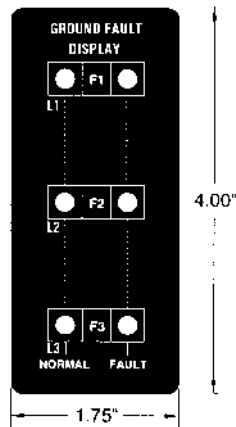

The ATC Diversified Electronics GFD Series is intended for the use on ungrounded systems to detect and indicate the phase of the first ground fault condition. This enables corrective action to avoid the potential hazards resulting from a second ground fault.

OPERATION

With nominal 3 phase line voltage applied, a flashing NORMAL green LED gives indication of a non-fault condition and integrity of the wire connection to the corresponding phase.

A flashing red LED gives positive FAULT indication of either a phase-to-ground fault, or a lost connection to the corresponding phase.

NOTE: Distributed capacitance to ground or equally loaded phases to ground will de-sensitize detection and will require lower phase-to-ground resistance to produce a FAULT indication.

SPECIFICATIONS

NOMINAL VOLTAGE	208-600 VAC, $\pm 10\%$, Phase-to-Phase, 50/60 Hz	
MAX. CONTINUOUS VOLTAGE	660 VAC, Phase-to-Phase	
WIRING ERROR PROTECTION	Yes	
DETECTION THRESHOLD	11.7 k Ω $\pm 20\%$ @ 50 Hz; 9.3 k Ω $\pm 20\%$ @ 60 Hz Single Phase-to-Ground	
DETECTOR INDUCED FAULT CURRENT	50 Hz	7.5 mA @ 600 VAC (1 Phase-to-Ground shorted)
	60 Hz	9 mA @ 600 VAC (1 Phase-to-Ground shorted)
FRESNEL LENS INDICATORS	Normal	(3) Green LEDs, 2 Flashes/Sec
	Fault	(3) Red LEDs, 2 Flashes/Sec
APPARENT POWER REQUIRED	50 Hz	2.5 VA @ 600 VAC
	60 Hz	3 VA @ 600 VAC
TEMPERATURE RATINGS	Operate	32° to 131°F (0° to +55°C)
	Storage	-49° to 185°F (-45° to +85°C)
ENCLOSURE	94V-0 Flame Retardant Black ABS Plastic, Panel Mount w/1/4" Plastic Electrical Conduit Adapter, Encapsulated for Environmental Protection	
TERMINATIONS	(4) 2 ft., 18 AWG, 600V, 105°C PVC Stranded Wire w/ Wire Pin Terminations, Jacketed with 1/8" Slit Nylon Corrugated Tubing, .556" O.D.	
WEIGHT	NET: 3.52 oz Shipping: 5.12 oz	

WIRING

